

1

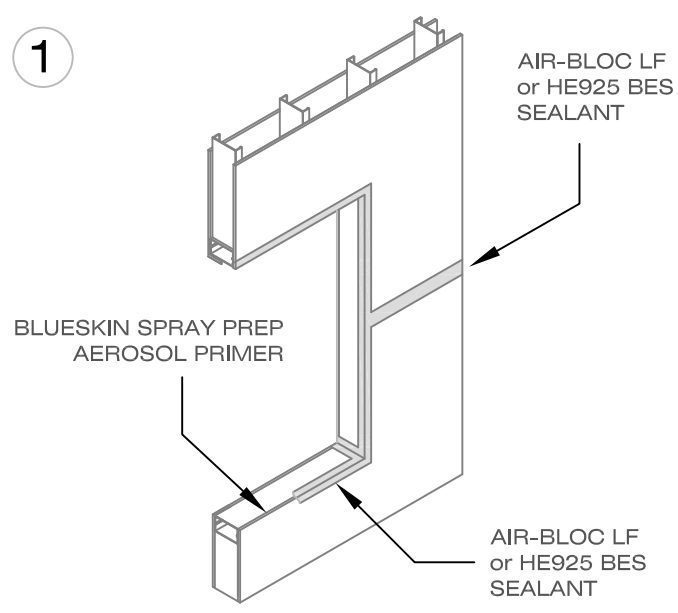

APPLY *BLUESKIN SPRAY PREP AEROSOL PRIMER* TO EXPOSED CUT EDGES OF GYPSUM BOARD AND ALLOW TO CURE. APPLY AIR-BLOC LF (OR HE925 BES SEALANT) TO ROUGH OPENING, JOINTS, SHEATHING SEAMS, VOIDS AND FASTENER HOLES PER THE APPLICABLE HENRY TECHNICAL DATA SHEET. EXTEND SEALANT 1" BEYOND ALL JOINTS. ALLOW TO CURE.

2

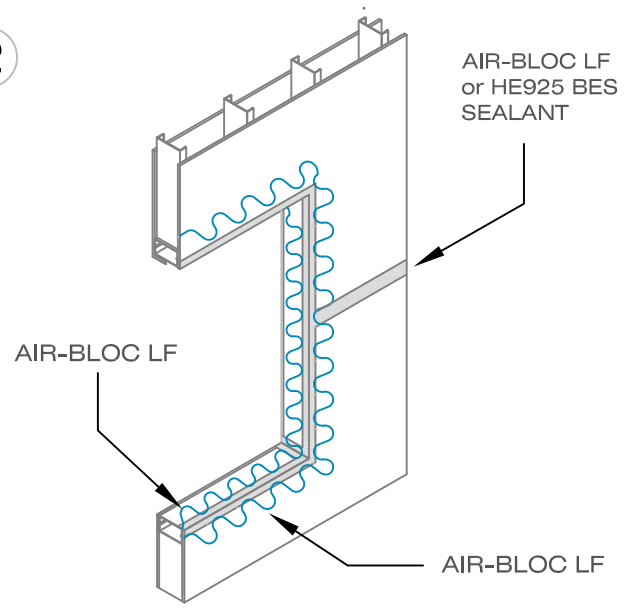

APPLY AIR-BLOC LF TO SUBSTRATE IN A SERPENTINE FASHION AROUND FACE OF WALL AND INSIDE OF ROUGH OPENING. NOTE: INSTALL SERPENTINE APPLICATION OF AIR-BLOC LF IN MANAGABLE QUANTITIES ONLY. AIR-BLOC LF MUST NOT SKIN OVER PRIOR TO TOOLING PROCEDURE DESCRIBED IN STEP 3 BELOW.

3

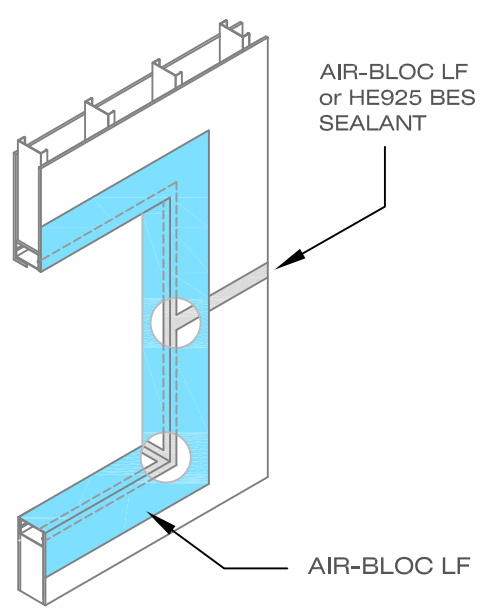

USING A TROWEL OR SPATULA, EVENLY SPREAD AIR-BLOC LF OVER ENTIRE ROUGH OPENING AND FACE OF WALL TO A DISTANCE OF 4 TO 6 INCHES. FINISHED WET FILM THICKNESS SHOULD BE AS SPECIFIED ON HENRY AIR-BLOC LF TECHNICAL DATA SHEET.

4

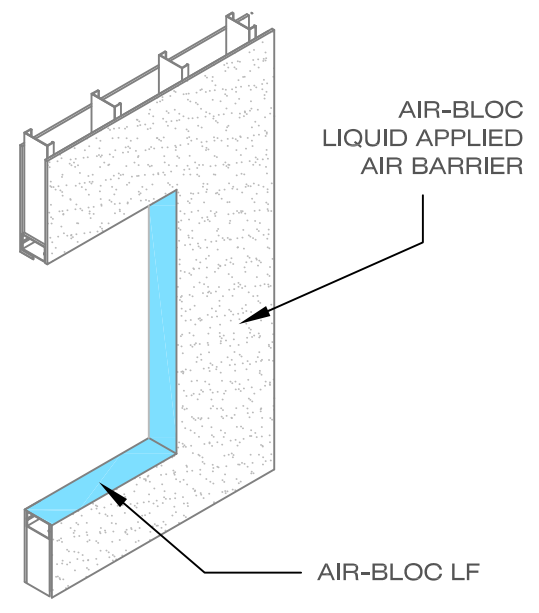

INSTALL AIR-BLOC AIR BARRIER MEMBRANE PER THE APPLICABLE HENRY TECHNICAL DATA SHEET. ALLOW AIR-BLOC MEMBRANE TO CURE PRIOR TO INSTALLATION OF WINDOW. INSTALL WINDOWS PER SPECIFICATION, WINDOW MANUFACTURER'S RECOMMENDATION OR INDUSTRY STANDARDS.



LIQUID APPLIED AIR BARRIER
EXTERIOR SHEATHING / PUNCH WINDOW OPENING

SCALE: N.T.S.
FIT TO PAPER

**AIR-BLOC LF
DETAIL**

AB-H142