

## Expansion Joint up to 12mm (1/2")

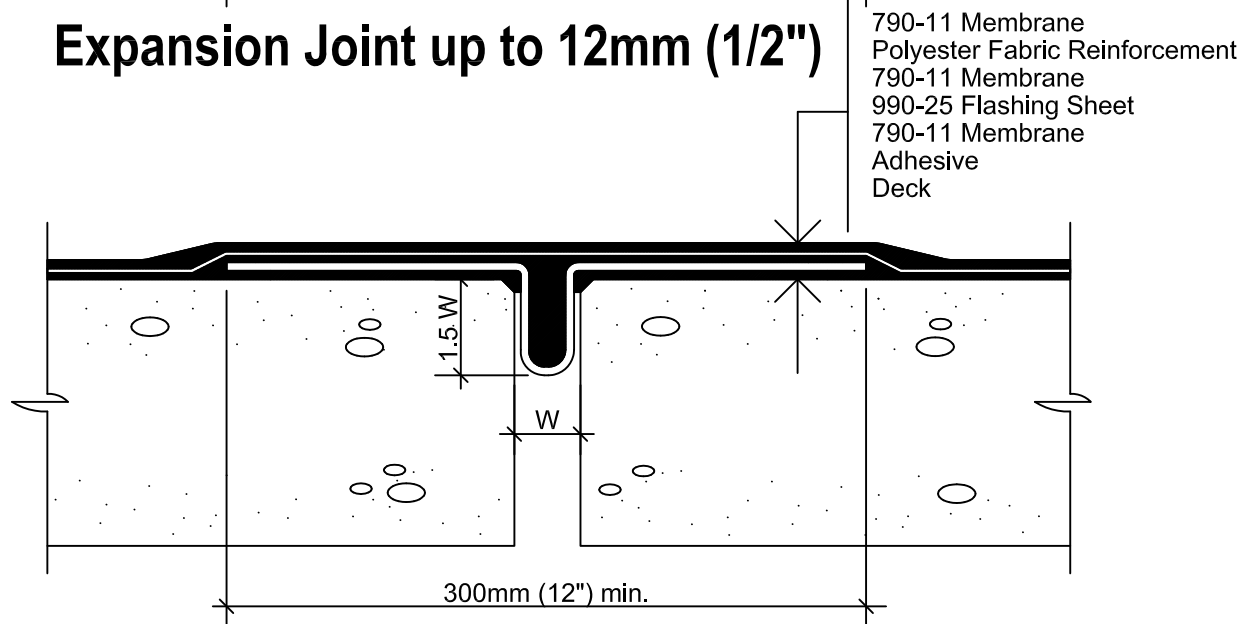

## Expansion Joint 12mm (1/2") to 50mm (2")

### Notes

1. Baker provides standard details for expansion joints as shown. However, it is recommended that designers use a monolithic prefabricated expansion joint when 'W' is larger than 50mm (2"); this provides the primary waterproofing at the expansion joint when used in conjunction with the waterproofing membrane system.
2. Where excessive movement or vibration is expected, the designer should consider using a termination bar mechanically fastened through the flashing sheet on 300mm (12") centres on both sides of the joint.

790-11 Waterproofing

## EXPANSION JOINTS

DECK TO DECK

Scale: N.T.S.

Plot: 1:5

Issued: 02-14-98

Revision: 04

# WPR-10B98



15 Walsend Drive, Toronto ON M1E 3X6  
Technical Services - 800-486-1278  
Email: techservices@henry.com  
www.ca.henry.com